

# SRP

Stewart-Rose Properties

# FOR LEASE



## Office/Warehouse

### Suite 1 & 2

- Available: 2447 SF
- Divisible to:
  - 1227 SF
  - 1220 SF
- 10 x 10 Bay Doors
- Convenient to Hwy 121 & I-35

### For Information Contact:

Larry Rose Jr.  
(972) 921-7579  
larry@s-rp.com

Stewart-Rose Properties  
Phone: (940) 365-3470  
Fax: (940) 365-1073  
www.s-rp.com

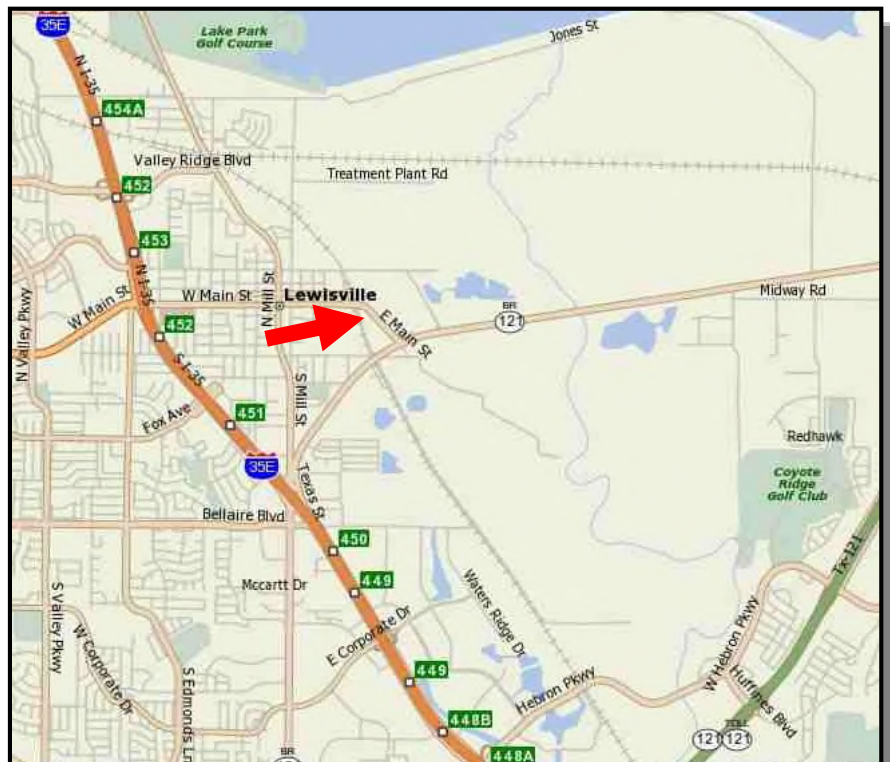

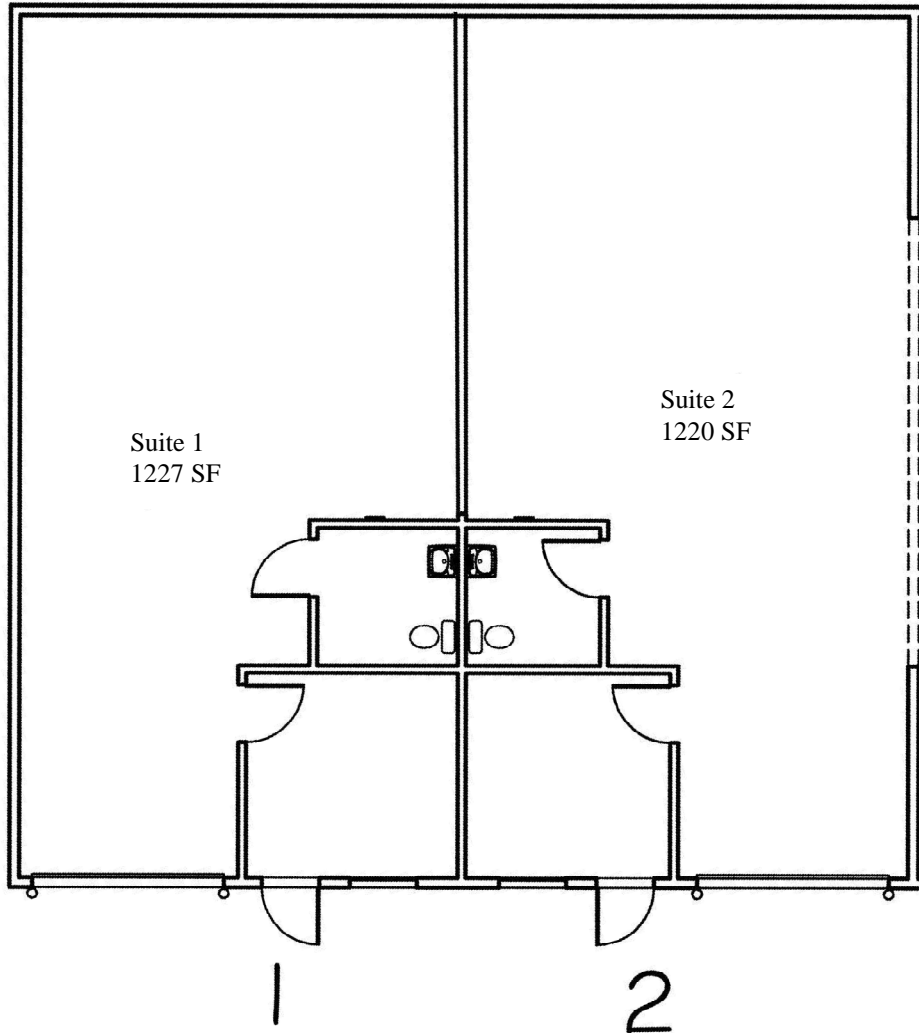



Larry Rose, Jr.  
(972) 921-7579  
[larry@s-rp.com](mailto:larry@s-rp.com)

[www.s-rp.com](http://www.s-rp.com)

Stewart-Rose Properties  
Phone: (940) 365-3470  
Fax: (940) 365-1073